

TEST REPORT

Report No.: B1379.01-602-44

Rendered to:

PROFORMANCE MANUFACTURING INC
Lone Rock, Wisconsin

PRODUCT TYPE: 71 x 60 Fiberglass Horizontal Sliding Window
SERIES/MODEL: ProStar/ECOSTAR Tilt-In Horizontal Slider

SPECIFICATION: AAMA/WDMA/CSA 101/I.S.2/A440-08, *NAFS - North American Fenestration Standard/Specification for Windows, Doors, and Skylights*
and
AAMA/WDMA/CSA 101/I.S.2/A440-05, *Standard/Specification for Windows, Doors, and Unit Skylights.*

Title	Summary of Results
Primary Product Designator AAMA/WDMA/CSA 101/I.S.2/A440-08	Class LC-PG40 Size Tested: 1803 x 1524 (71 x 60)-HS
AAMA/WDMA/CSA 101/I.S.2/A440-05	HS-C40 1803 x 1524 (71 x 60)
Design Pressure	±1920 Pa (±40.10 psf)
Air Infiltration	0.8 L/s/m ² (0.15 cfm/ft ²)
Canadian Air Infiltration/Exfiltration Level	A2
Water Penetration Resistance Test Pressure	360 Pa (7.52 psf)

Test Completion Date: 07/08/2011

Reference must be made to Report No. B1379.01-602-44, dated 08/08/11 for complete test specimen description and detailed test results.

1.0 Report Issued To: Proformance Manufacturing, Inc.
P.O. Box 58/750 North County Line Road
Lone Rock, Wisconsin 53556

2.0 Test Laboratory: Architectural Testing, Inc.
5906 Saxon Avenue
Schofield, Wisconsin 54476
715-241-8624

3.0 Project Summary:

3.1 Product Type: 71 x 60 Fiberglass Horizontal Sliding Window

3.2 Series/Model: ProStar/ECOSTAR Tilt-In Horizontal Slider

3.3 Compliance Statement: Results obtained are tested values and were secured by using the designated test method(s). The specimen tested successfully met the performance requirements for a **Class LC-PG40 Size Tested: 1803 x 1524 (71 x 60)-HS and HS-C40 1803 x 1524 (71 x 60)** rating.

3.4 Test Dates: 07/07/2011 - 07/08/2011

3.5 Test Location: Architectural Testing, Inc. test facility in Schofield, Wisconsin.

3.6 Test Sample Source: The test specimen was provided by the client.

3.7 Drawing Reference: The test specimen drawings have been reviewed by Architectural Testing and are representative of the test specimen(s) reported herein. Test specimen construction was verified by Architectural Testing per the drawings located in Appendix C. Any deviations are documented herein or on the drawings.

3.8 List of Official Observers:

<u>Name</u>	<u>Company</u>
Jerry Beranek	Proformance Manufacturing, Inc.
Jeff Zibton	Architectural Testing, Inc.
Eric Jehn	Architectural Testing, Inc.

4.0 Test Specification(s):

AAMA/WDMA/CSA 101/I.S.2/A440-08, *NAFS - North American Fenestration Standard/Specification for Windows, Doors, and Skylights*

AAMA/WDMA/CSA 101/I.S.2/A440-05, *Standard/Specification for Windows, Doors, and Unit Skylights.*

5.0 Test Specimen Description:

5.1 Product Sizes:

Overall Area: 2.8 m ² (29.6 ft ²)	Width		Height	
	millimeters	Inches	millimeters	inches
Overall size	1803	71	1524	60
Exterior sash	876	34-1/2	1422	56
Interior sash	876	34-1/2	1448	57
Screen	1705	67-1/8	1429	56-1/4

5.2 Frame Construction:

Frame Member	Material	Description
Head, sill and jambs	Fiberglass	Pultruded

	Joinery Type	Detail
All corners	Mitered	The corner keys were adhered in place with Nova Gard 900-200 2-part bonding adhesive. Each miter employed silicone sealant.

5.3 Sash Construction:

Sash Member	Material	Description
Sash stop	ABS	Extruded
Interlock	ABS	Extruded
Top rail, bottom rail and stiles	Fiberglass	Pultruded

	Joinery Type	Detail
All corners	Mitered	The corner keys were adhered in place with Nova Gard 900-200 2-part bonding adhesive.

5.4 Weatherstripping:

Description	Quantity	Location
0.187" backed by 0.290" high pile with center fin	1 Row	Exterior perimeter of both sash
0.187" backed by 0.290" high pile with center fin	1 Row	Interior perimeter of both sash

5.0 Test Specimen Description: (Continued)

5.4 Weatherstripping: (Continued)

Description	Quantity	Location
0.187" backed by 0.290" high pile with center fin	1 Row	Exterior sash at interior face of sash interlock
1.000" wide by 1.000" long by 0.250" high wool pile	1	Sill end of sash vertical interlock at exterior sash
0.500" wide by 1.000" long by 0.438" high wool pile with double fin	1	Sill end of sash vertical interlock at interior sash

5.5 Glazing:

Glass Type	Spacer Type	Interior Lite	Exterior Lite	Glazing Method
19.1 mm (3/4") IG	12.7 mm (1/2") steel spacer system	3.2 mm (1/8") annealed	3.2 mm (1/8") annealed	The glass was set from the exterior against glazing tape. ABS glazing beads were used at the exterior.

Location	Quantity	Daylight Opening		Glass Bite
		millimeters	inches	
Exterior sash	1	770 x 1321	30-5/16 x 52	5/8"
Interior sash	1	770 x 1346	30-5/16 x 53	5/8"

5.6 Drainage:

Drainage Method	Size	Quantity	Location
Slot	0.250" x 1.375"	2	Ends of interior sash track at sill.
Slot	0.250" x 1.375"	2	1-1/2" from frame edge under the sill.
Hole	0.250"	3	Sill exterior track 7-1/2" from frame edges and at center.
Hole	0.250"	2	Bottom of both sash 3-7/16" from ends of bottom rail.

5.0 Test Specimen Description: (Continued)

5.7 Hardware:

Description	Quantity	Location
Sweep lock	2	4-1/2" from top and bottom at meeting stile of interior sash.
Keeper	2	Adjacent to lock on exterior sash.
Glide pads	4	1-3/8" From corners at bottom rails of both sash.
Tilt latch	4	Ends of top rail on both sash.

5.8 Reinforcement: No reinforcement was utilized.

5.9 Screen Construction:

Frame Material	Corner Construction	Mesh Type	Mesh Attachment Method
Aluminum	Keyed	Fiberglass	Rubber screen spline

6.0 Installation:

The specimen was installed into a Spruce-Pine-Fir wood buck. The rough opening allowed for a 1/4" shim space. The exterior perimeter of the window was sealed with silicone.

Location	Anchor Description	Anchor Location
Frame head	#8 x 3" long screw	One anchor at the meeting rail
Frame jambs	#8 x 3" long screw	One anchor 4" from each corner and one 35-1/2" from the sill corner

7.0 Test Results: The temperature during testing was 21°C (70°F). The results are tabulated as follows:

Title of Test	Results	Allowed	Note
Operating Force, per ASTM E 2068	Initiate motion: 93 N (21 lbf)	Report only	
	Maintain motion: 85 N (19 lbf)		
	Latches: 13 N (3 lbf)	115 N (25 lbf) max.	
	Locks: 31 N (7 lbf)	100 N (22.5 lbf) max.	
		100 N (22.5 lbf) max.	

7.0 Test Results: (Continued)

Title of Test	Results	Allowed	Note
Air Leakage, Infiltration per ASTM E 283 at 75 Pa (1.57 psf)	0.76 L/s/m ² (0.15 cfm/ft ²)	1.5 L/s/m ² (0.3 cfm/ft ²) max.	1
Air Leakage, Exfiltration per ASTM E 283 at 75 Pa (1.57 psf)	0.71 L/s/m ² (0.14 cfm/ft ²)	1.5 L/s/m ² (0.3 cfm/ft ²) max.	1
Canadian Air Infiltration/Exfiltration Level	A2	N/A	
Water Penetration, per ASTM E 547	N/A	N/A	3
Uniform Load Deflection, per ASTM E 330	N/A	N/A	3
Uniform Load Structural, per ASTM E 330	N/A	N/A	3
Forced Entry Resistance, per ASTM F 588, Type: A - Grade: 10	Pass	No entry	
Deglazing, per ASTM E 987 Operating direction, 320 N (70 lbf) Remaining direction, 230 N (50 lbf)	Pass Pass	Meets as stated Meets as stated	
Optional Performance			
Water Penetration, per ASTM E 547 at 360 Pa (7.52 psf)	Pass	No leakage	2
Uniform Load Deflection, per ASTM E 330 taken at meeting stile +1920 Pa (+40.10 psf) -1920 Pa (-40.10 psf)	11.9 mm (0.47") 12.4 mm (0.49")	Report Only	4, 5, 6
Uniform Load Structural, per ASTM E 330 taken at meeting stile +2880 Pa (+60.15 psf) -2880 Pa (-60.15 psf)	0.3 mm (0.01") <0.3 mm (<0.01")	4.3 mm (0.17") max. 4.3 mm (0.17") max.	5, 6

7.0 Test Results: (Continued)

Note 1: The tested specimen meets (or exceeds) the performance levels specified in AAMA/WDMA/CSA 101/I.S.2/A440 for air leakage resistance.

Note 2: With and without insect screen.

Note 3: The client opted to start at a pressure higher than the minimum required. Test results are reported under Optional Performance.

Note 4: The deflections reported are not limited by AAMA/WDMA/CSA 101/I.S.2/A44 for this product designation. The deflection data is recorded in this report for special code compliance and information only.

Note 5: Loads were held for 10 seconds.

Note 6: Tape and film were used to seal against air leakage during structural testing. In our opinion, the tape and film did not influence the results of the test.

The service life of this report will expire on the stated Test Record Retention End Date, at which time such materials as drawings, data sheets, samples of test specimens, copies of this report, and any other pertinent project documentation, shall be discarded without notice.

If test specimen contains glazing, no conclusions of any kind regarding the adequacy or inadequacy of the glass in any glazed test specimen(s) can be made. This report does not constitute certification of this product nor an opinion or endorsement by this laboratory. It is the exclusive property of the client so named herein and relates only to the specimen(s) tested. This report may not be reproduced, except in full, without the written approval of Architectural Testing, Inc.

For ARCHITECTURAL TESTING, Inc.

Eric J. Jehn
Technician

Jeffrey M. Zibton
Project Manager

EJJ:asm

Attachments (pages): This report is complete only when all attachments listed are included.

Appendix-A: Alteration Addendum (1)

Appendix-B: Photographs (1)

Appendix-C: Drawings (19)

Appendix A

Alteration Addendum

Note: *No alterations were required.*

Appendix B
Photographs

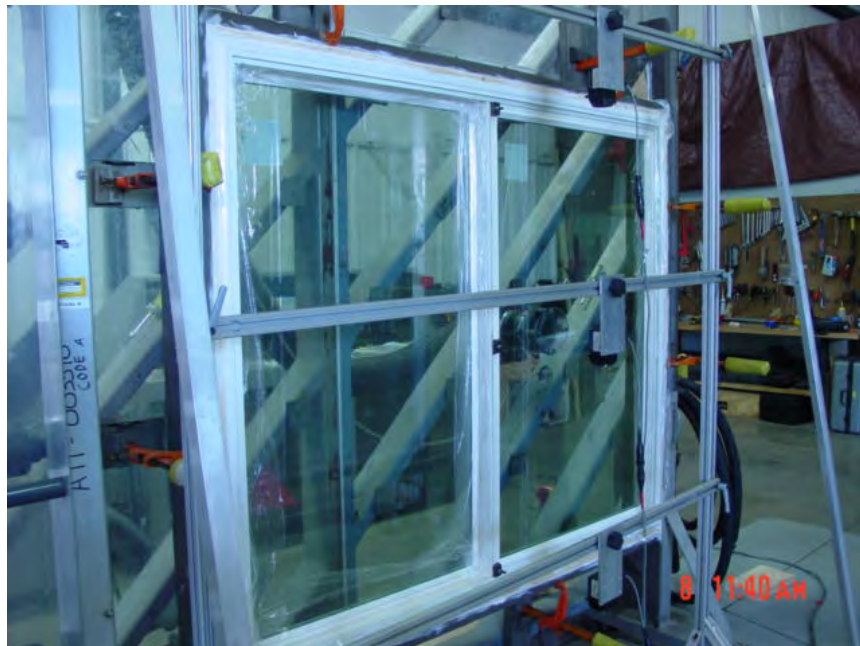

Photo # 1
Structural loading on horizontal slider.

Test Report No.: B1379.01-602-44
Report Date: 08/08/11
Test Record Retention End Date: 07/08/15

Appendix C

Drawings

BOM for 71X60 Slider for AAMA testing for 7-13-2011

Description	Vendor	Part #	
→ Weep Doors	Ashland Hardware	64400-001	
→ Locks (White)	Ashland Hardware	D1000AL-01	X
→ Keeper (White)	Ashland Hardware	14161-999-001	X
→ Lift Handle (White)	Ashland Hardware	13314-999-01-BG	X
Glides	Ashland Hardware	94-05-30-BW	
→ Left Tilt Latches (White)	Ashland Hardware	80290	X
→ Right Tilt Latches (White)	Ashland Hardware	80291	X
→ Left Toggle tilt latches	Ashland Hardware	83100	x
→ Right Toggle tilt latches	Ashland Hardware	82100	x
→ Tilt Latch Reinforcement	Ashland Hardware	14186-385	
→ Keys Sash	Flambeau	817710AE	X
→ Keys Frame	Flambeau	817711AE	X
→ Frame Material (White)	Teel Plastics	97097001	X
→ Sash Material (White)	Teel Plastics	97097002	X
→ Glazing Bead	Teel Plastics	P0136	X
Interlocks	Teel Plastics	P0135	X
Balance Covers	Teel Plastics	P0140	X
→ Sash Stiffener	Sureview	SV19	X
Weather strip	Ultra Fab	W33291NG	X
Weather strip	Ultra Fab	W131319W0000	X



Architectural Testing

Test sample complies with these details.
Deviations are noted.

Report# B1379.01

Date 7/28/11

Tech EJ

REVISIONS				
ZONE	REV	DESCRIPTION	DATE	APPROVED
	01	Final draft	11.17.2010	

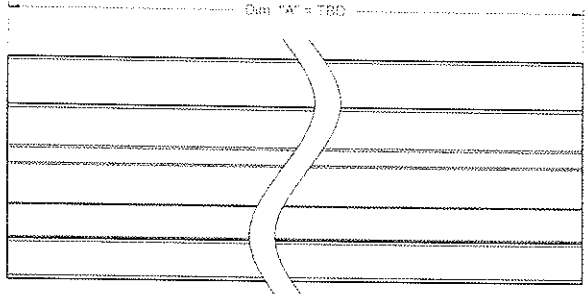

Trim Detail
Scale: None

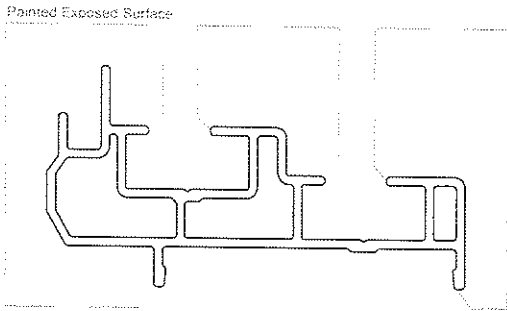

Customer Approval

Sign name on line above: _____ Date: _____

Print name on line above: _____

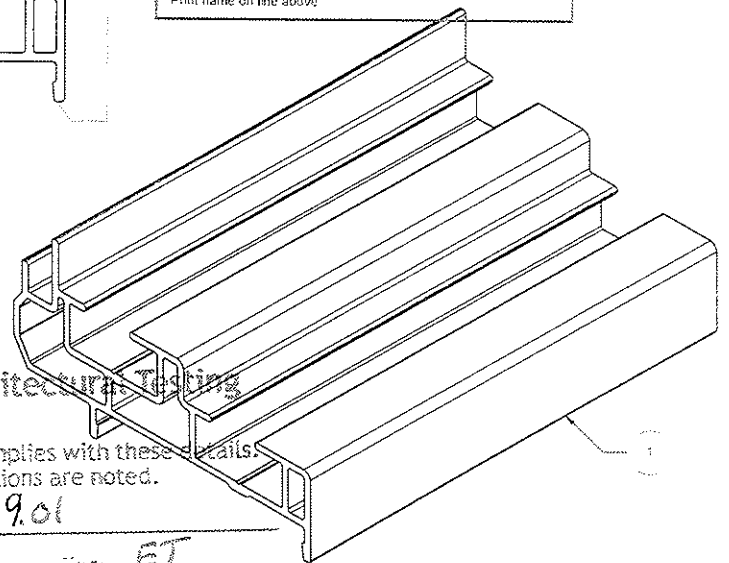

Test sample complies with these details.
Deviations are noted.

Report# B1279.01

Date 7/28/11 Tech EJ

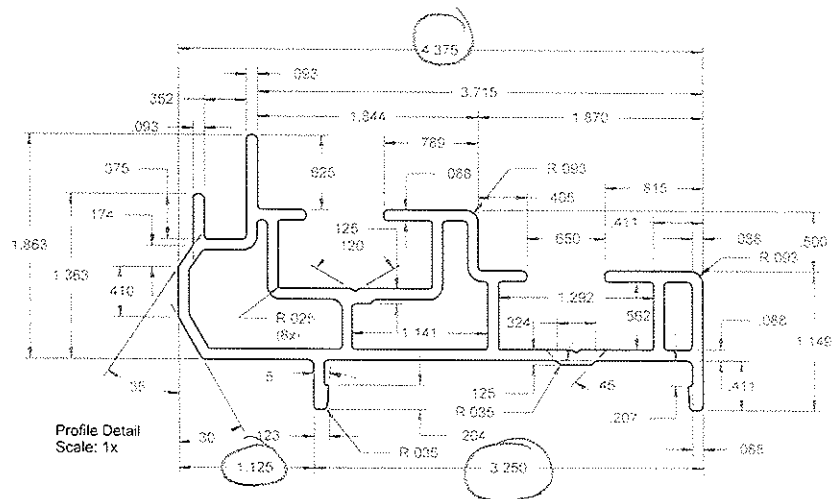

Profile Detail
Scale: 1x

Item #	Part Name	Cost Center	Revision	Comment
1	DH Frame Profile			Area: 1.363, Outer Perimeter: 19.420", Inner Perimeter: 10.010"

Note: Industry Standard Tolerances Unless Otherwise Specified The contents of this document or electronic media are confidential and proprietary information of Performance Manufacturing Inc. Distribution or reproduction of this information without the express written consent of Performance Manufacturing Inc. is prohibited. © 2010 PMI. All rights reserved.	DRAWN PMI Engineering	DATE 11.17.2010		Performance Manufacturing, Inc. 750 North County Line Road Lone Rock, WI 53556 www.pmi-windows.com 608.583.7200 608.583.7060 Fax	
	CHECKED				SIZE B
	MFG		SCALE As Noted	Directory NBO\PMI\Eng\Double Hung	SHEET 1 of 1

Double Hung Head Key - Parts A & B Assembly

CI STAMP SIGNATURE

Company _____

Signature _____

Printed Name _____

Date _____

- Notes:
1. Material: ABS
 2. Finish: EBHM
 3. Color: Natural
 4. Nominal Wall Thickness: 0.089"
 5. Tooling Note: Radius corners up to 0.031" as needed except where it would cause interference between mating surfaces.

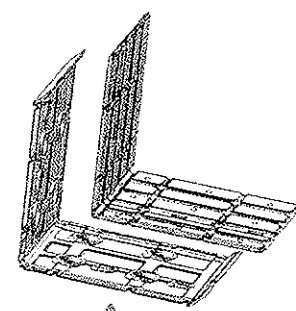

Architectural Testing

Test sample complies with these details.
Deviations are noted.

Report # **B1379 01**
Date **7/29/11** Tech **ET**

REV	DATE	BY	DESCRIPTION
1	7/29/11	ET	Added .037 bumps
0	1-29-11	RDL	Released for Tooling

0.030

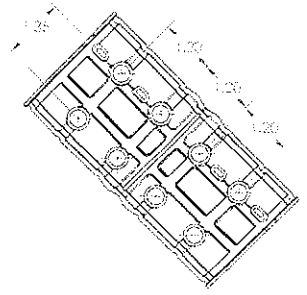
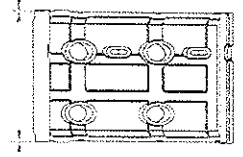

VIEW A-A

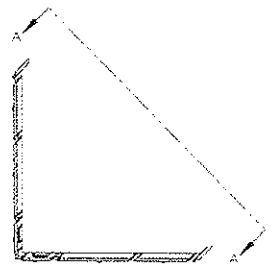
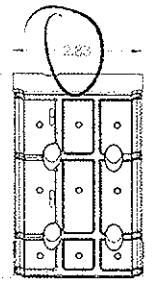

Double Hung Head Key - Part A (PN DH Head Part A)

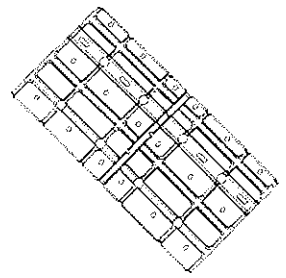
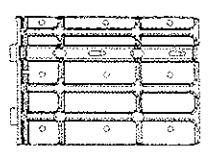

VIEW B-B

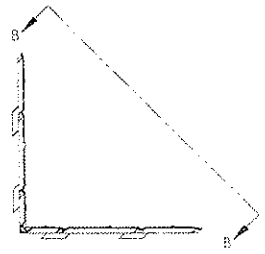
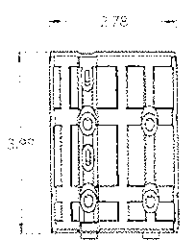

Double Hung Head Key - Part B (PN DH Head Part B)

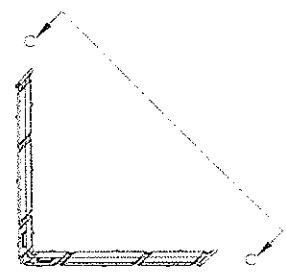
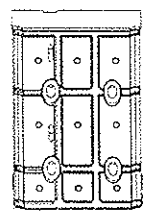

VIEW C-C

PROPRIETARY AND CONFIDENTIAL
This drawing is the property of Flambeau Inc. and is not to be distributed outside the company without the written permission of Flambeau Inc.

REV	DESCRIPTION	DATE	BY	APPR
1	Added .037 bumps	5-20-11	RDL	
0	Released for Tooling	1-29-11	RDL	

SHT

FLAMBEAU, INC.
111 LYNN AVENUE BARABOO, WI 53213 PH: 608/336-6561

Scale: 1/2" = 1"

Material: ABS

Color: Natural

Finish: EBHM

Part No: NA

Part Name: DH Head

Description: **Double Hung Head Key Assembly**

Customer: PMI

Part No: **S-10341**

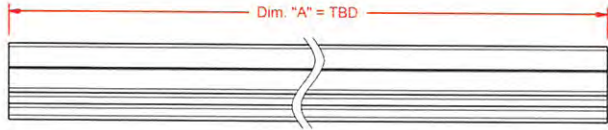

Trim Detail
Scale: 1x

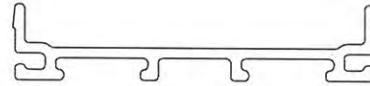

REVISIONS				
ZONE	REV	DESCRIPTION	DATE	APPROVED
	.01	Final draft	11.17.2010	

Customer Approval

Sign name on line above

Date

Print name on line above

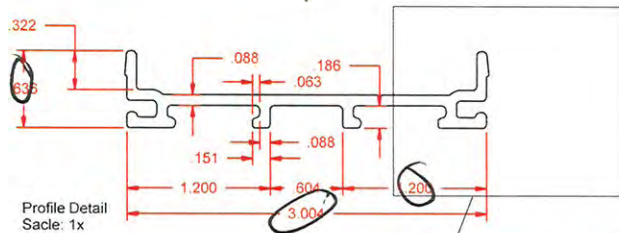

Profile Detail
Scale: 1x

Architectural Testing

Test sample complies with these details.
Deviations are noted.

Report# B1379.01
Date 7/28/11 Tech ET

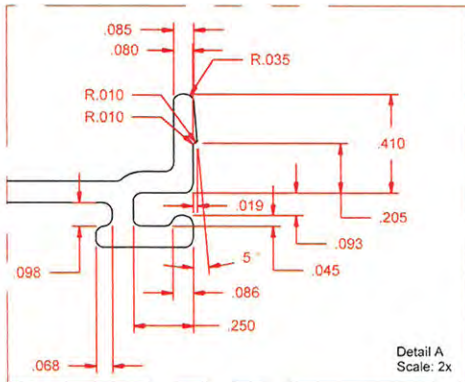
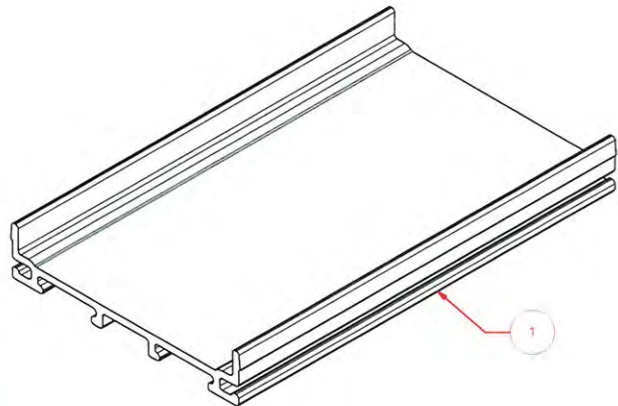

Detail A
Scale: 2x

Item #	Part Name	Cost Center	Revision	Comment
1	Frame Cap	Area: .462, Perimeter: 10.201		
Note: Industry Standard Tolerances Unless Otherwise Specified.		DRAWN PMI Engineering	DATE 11.17.2010	<p>Performance Manufacturing, Inc 750 North County Line Road Lone Rock, WI 53556 www.pmi-windows.com 608.583.7200 608.583.7060 Fax</p>
The contents of this document or electronic media are confidential and proprietary information of Performance Manufacturing, Inc. Distribution or reproduction of this information without the express written consent of Performance Manufacturing, Inc. is prohibited. © 2010 PMI All rights reserved.		CHECKED		
		QA		
		MFG		
		APPROVED		
SIZE B	DWG NO PMI-003.01	DWG Name Frame Cap	REV .01	
SCALE As Noted		Directory NBO\PMI\Eng\Accessory\Frame		SHEET 1 of 1

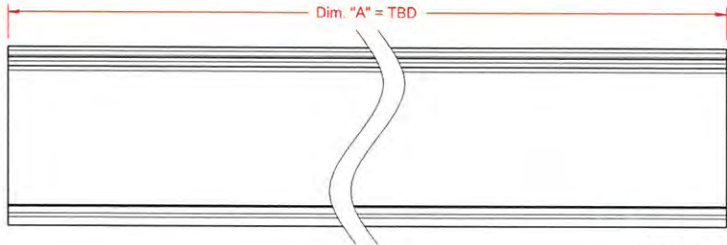

Trim Detail
Scale: 1x

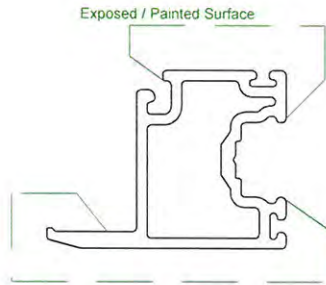

REVISIONS				
ZONE	REV	DESCRIPTION	DATE	APPROVED
	.01	Final draft	11.17.2010	

Customer Approval

Sign name on line above _____ Date _____

Print name on line above _____

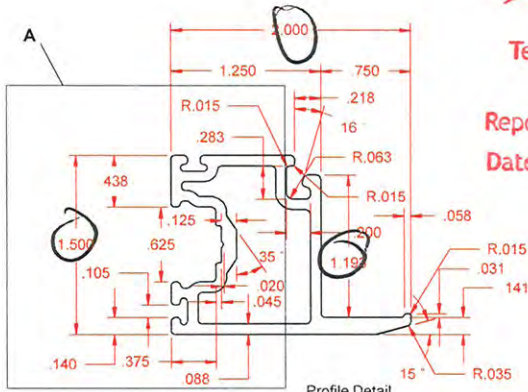

Profile Detail
Scale: 1x

Architectural Testing

Test sample compliant with these details.
Deviations are noted.

Report# B1379.01
Date 7/28/11 Tech EJ

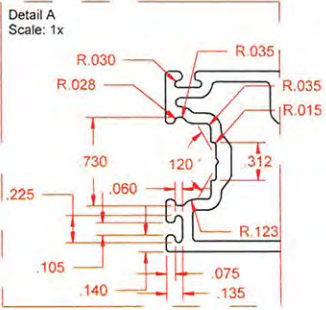
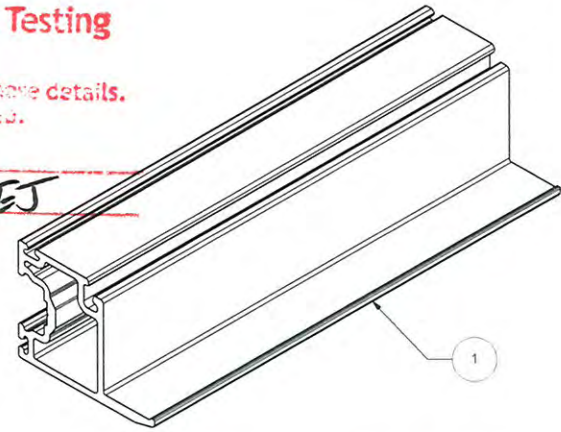

Detail A
Scale: 1x

Item #	Part Name	Cost Center	Revision	Comment
1	DH Sash Profile	Area: .677, Outer Perimeter: 9.112", Inner Perimeter: 4.947"		
Note: Industry Standard Tolerances Unless Otherwise Specified. The contents of this document or electronic media are confidential and proprietary information of Performance Manufacturing, Inc. Distribution or reproduction of this information without the express written consent of Performance Manufacturing, Inc. is prohibited © 2010 PMI. All rights reserved.		DRAWN PMI Engineering CHECKED GA MFG APPROVED	DATE 11.17.2010	 Performance Manufacturing, Inc 750 North County Line Road Lone Rock, WI 53556 www.pmi-windows.com 608.583.7200 608.583.7060 Fax
SIZE B	DWG NO. PMI-002.01	DWG Name. Double Hung Sash Profile	REV .01	
SCALE As Noted	Directory NBO\PMI\Eng\Double_Hung	SHEET 1 of 1		

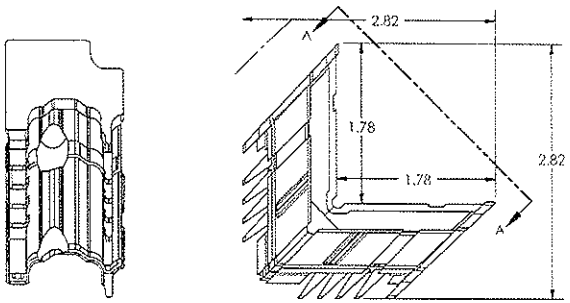
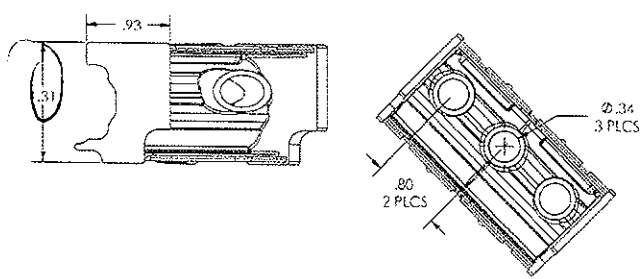

Double Hung Sash Key - Part A (PN DH Sash Part A)

Double Hung Sash Key - Parts A & B Assembly

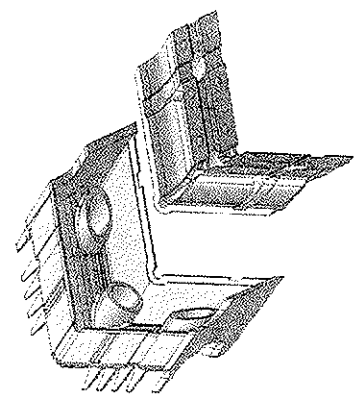

CUSTOMER SIGN-OFF	
Company	
Signature	
Printed Name	
Date	

- Notes
1. Material: A6S
 2. Finish: EDM
 3. Color: Natural
 4. Nominal Wall Thickness: 0.080"
 5. Tooling Note: Radius corners up to 0.020 as needed except where it would cause interference between mating surfaces.



Test sample complies with these details.
Deviations are noted.

Report# B137901
Date 7/29/11 Tech ES

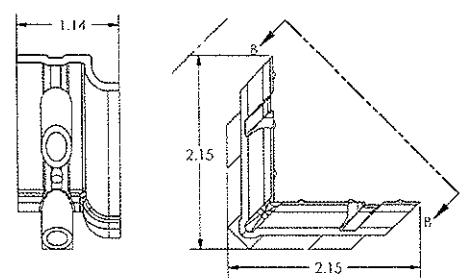
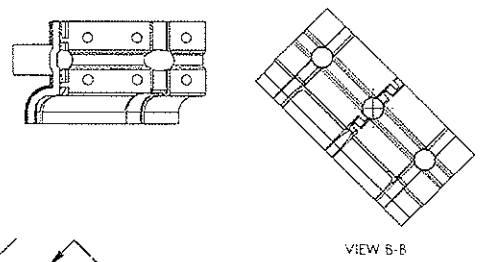
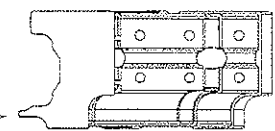

Double Hung Sash Key - Part B (PN DH Sash Part B)

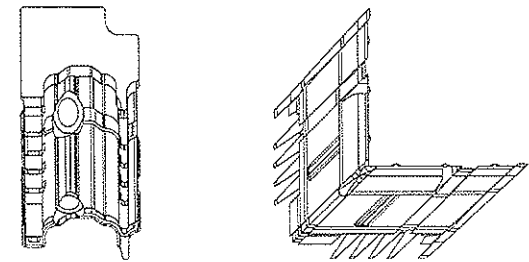

<small>PROPRIETARY AND CONFIDENTIAL THIS DOCUMENT IS UNCLASSIFIED DATE 08-11-2010 BY 60322 UCBAW/SJS/STP REASON: EXECUTIVE ACTION</small>				FLAMBEAU, INC. <small>321 LYNN AVENUE DANABURG, WI 53513 P1110201350-0001</small>	
SHT 1		Scale 1:1		DATE 11/20/11	
OF 1		DESCRIPTION Double Hung Sash Key Assembly		DATE 11/20/11	
REV 0		DESCRIPTION Released for Tooling		DATE 1-20-11	
ECR ---		BY RDL		APPROVED ---	
REVISIONS					
DATE ---		BY ---		APPROVED ---	
DESCRIPTION ---		DATE ---		APPROVED ---	
DATE ---		BY ---		APPROVED ---	
DESCRIPTION ---		DATE ---		APPROVED ---	

FLAMBEAU, INC. <small>321 LYNN AVENUE DANABURG, WI 53513 P1110201350-0001</small>	
Scale 1:1	DATE 11/20/11
DESCRIPTION Double Hung Sash Key Assembly	DATE 11/20/11
REV 0	DESCRIPTION Released for Tooling
ECR ---	BY RDL
REVISIONS	
DATE ---	BY ---
DESCRIPTION ---	DATE ---
DATE ---	BY ---
DESCRIPTION ---	DATE ---

PMI S-10340

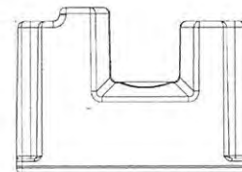
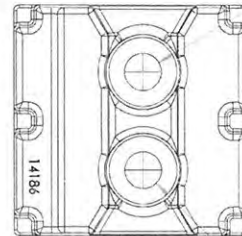
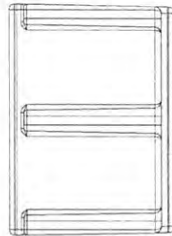
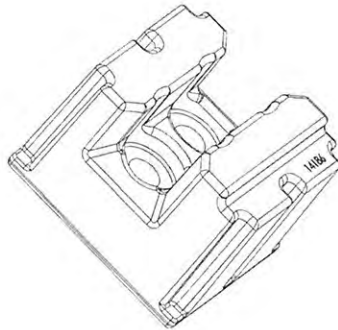

Architectural Testing

**Test sample complies with these details.
Deviations are noted.**

Report# B1379.02
Date 7/28/11 Tech EJ

NOTES:

1. C-LEVEL PART FOR CUSTOMER REFERENCE ONLY.
2. E-LEVEL PART TO BE USED TO CONTROL MANUFACTURING PROCESS.

APPLICABLE SPECIFICATIONS

DRAWN: MAT
CHECKED: DATE: 7-22-11

TITLE: JAMB REINFORCEMENT

SCALE: 2:1 MATERIAL DESCRIPTION / (TODD) INFORMATION: PC

ACTUAL MODEL WEIGHT: .0246 LBS.

PERMISSIBLE TOLERANCES UNLESS OTHERWISE SPECIFIED: RAW TEMPER EDGE NO.

LINEAR X = ± .030 .XX = ± .015 .XXX = ± .005 / ANGULAR X = ± 1° .X.X = ± 5"

EXPERIMENTAL NO. XB- SHEET C 1 OF 1 PART NO. C-14186 REV. -

This document and the information and designs thereon are proprietary and confidential and shall not be reproduced or disclosed in whole or in part without the prior written consent of Ashland. Use of this document is limited strictly to the purposes for which the document has been furnished.

Ashland

MOCKFORD ILLINOIS 61135-7018

APPROVED FOR TOOLING: DATE:

APPROVED FOR PRODUCTION: DATE:

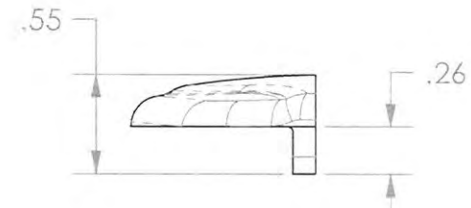
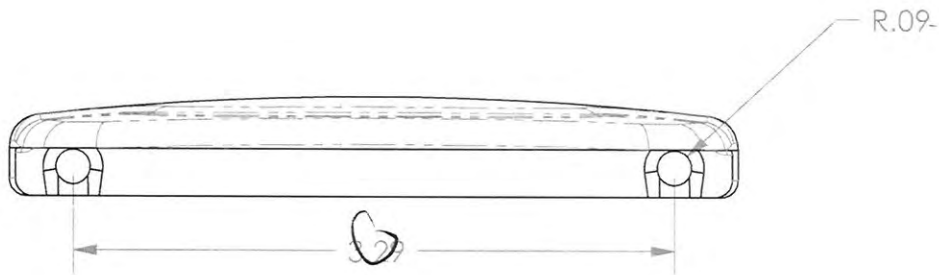
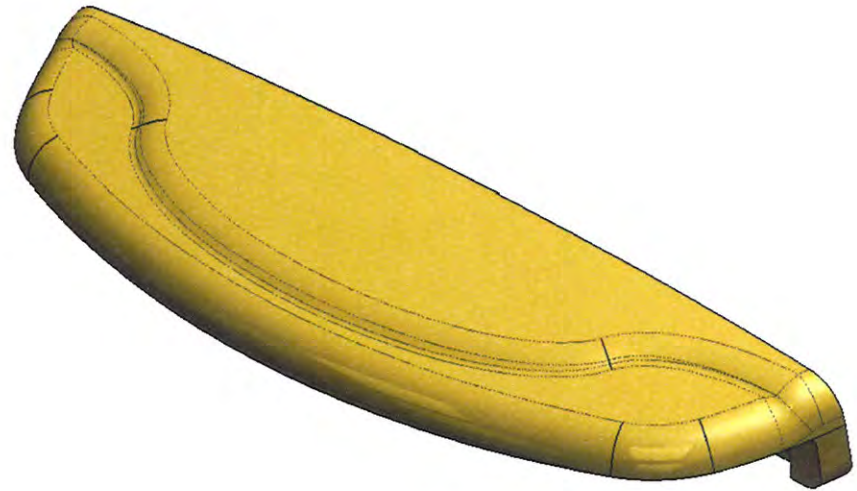
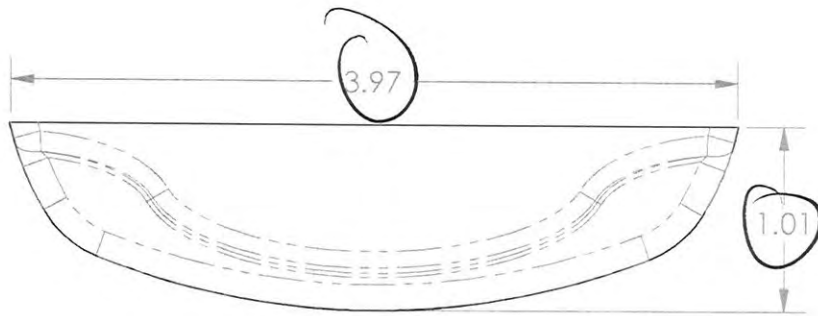

Test sample complies with these details.
Deviations are noted.

Report# B1379.01
Date 7/28/11 Tech ES

790 WEST COMMERCIAL AVENUE
LOWELL, INDIANA 46356
TELEPHONE NUMBER (219) 696-5950
24 HR. FAX (800) 626-1758

SASH LIFT, AHS DESIGN

MATERIAL: ZAMAK 3
DRAWN BY: -
CUBIC INCHES: -

DATE: 1/10/02

COMPONENT: -

CUSTOMER: -

PROJ #: -

~ NOTICE ~
THIS DRAWING IS THE
PROPERTY OF ASHLAND
PRODUCTS. DESIGN
CONCEPT & INFORMATION
MAY NOT BE REPRODUCED
USED OR DISCLOSED
WITHOUT WRITTEN
PERMISSION FROM ASHLAND

TOLERANCES UNLESS
OTHERWISE SPECIFIED
DECIMALS ±TOLERANCE
1 PLC. - .XXX .030
2 PLC. - .XXX .015
3 PLC. - .XXX .005
±TOLERANCE GREATER THAN 1.000
AS SHOWN PER INCH

DIMENSIONS ARE IN INCHES
UNLESS OTHERWISE
SPECIFIED ON DRAWING
DO NOT SCALE DRAWING

SCALE = 1:1 SHEET: 1 of 1

ASHLAND PART NUMBER

Q-13314-P-034

PRINT DATE: -

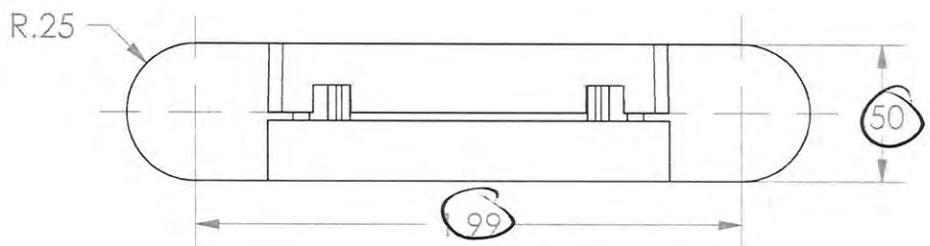
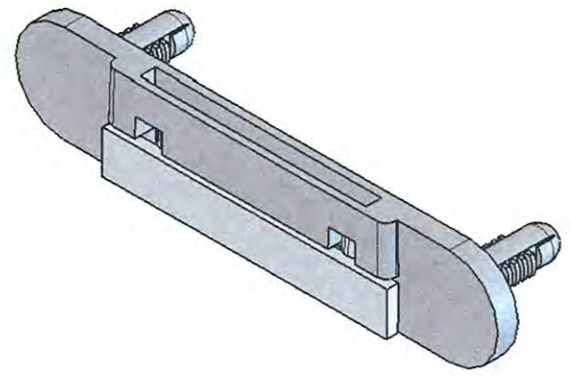
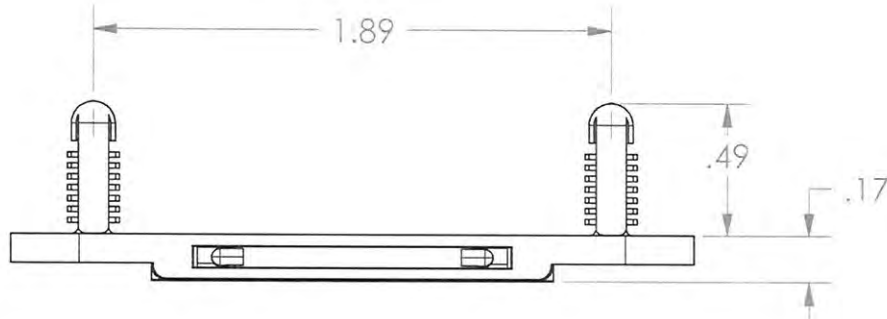

Architectural Testing
 Test sample complete with these details. Deviations are noted.
 Report# B1379.01
 Date 7/28/11 Tech EJ

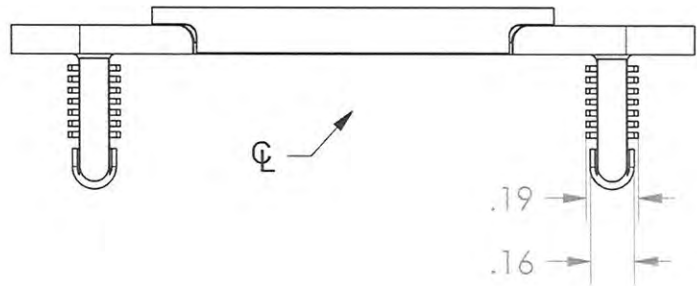

790 WEST COMMERCIAL AVENUE
 LOWELL, INDIANA 46356
 TELEPHONE NUMBER (219) 696-5950
 24 HR. FAX (800) 626-1758

WEEP HOUSING & FLAP ASSEMBLY

MATERIAL: NYLON 6 COLOR: -
 CUSTOMER: -
 DRAWN BY: MAT DATE: 9-14-09 CK. BY: - DATE: -
 USED IN ASSY: - PROJ #: - PROTO. #: -
 CUBIC INCHES: COMPONENT: - CAVITATION: -
 ~ NOTICE ~
 THIS DRAWING IS THE PROPERTY OF ASHLAND HARDWARE SYSTEMS. DESIGN CONCEPT & INFORMATION MAY NOT BE REPRODUCED USED OR DISCLOSED WITHOUT WRITTEN PERMISSION FROM ASHLAND.
 TOLERANCES UNLESS OTHERWISE SPECIFIED
 DECIMALS ±TOLERANCE
 1 PLC. - .X .030
 2 PLC. - .XX .015
 3 PLC. - .XXX .005
 ±TOLERANCE GREATER THAN 1.000 AS SHOWN PER INCH
 DIMENSIONS ARE IN INCHES UNLESS OTHERWISE SPECIFIED ON DRAWING
 DO NOT SCALE DRAWING
 SCALE = 1:1 SHEET: 1 of 1
 ASHLAND PART NUMBER

C-64400

PRINT DATE: 9-14-09

NOTES:

1. C-LEVEL PRINT FOR CUSTOMER REFERENE ONLY, E-LEVEL PRINT TO CONTROL MANUFACTURING PROCESS.
2. PART IS ϕ SYMMETRIC

PATENT NUMBER: - STATUS: - INHERITED PATENTS: -

~ PATENT INFORMATION ~

PART/DWG. NO.
C-14161

ISSUE DATE
7-19-11

REV. -
FILE NO.

CT ↓

RT

ECO #	LP	REVISION DESCRIPTION	INITIALS	DATE
-	-	Released Drawing	MAT	7/19/11

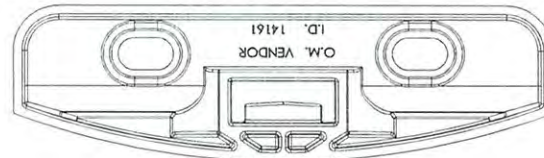
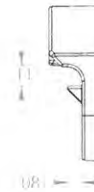
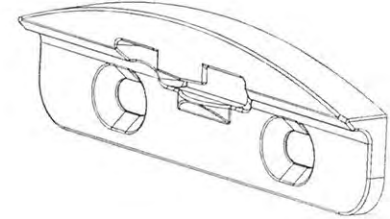
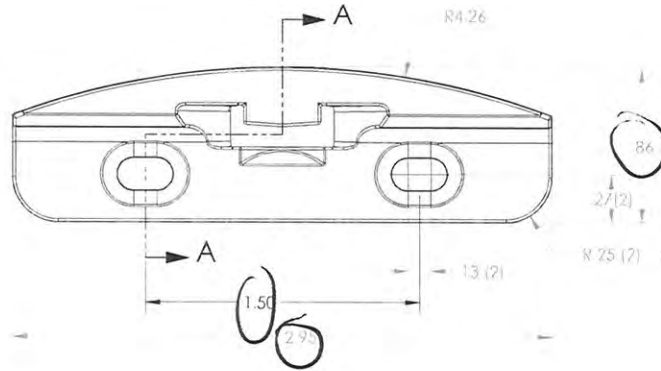
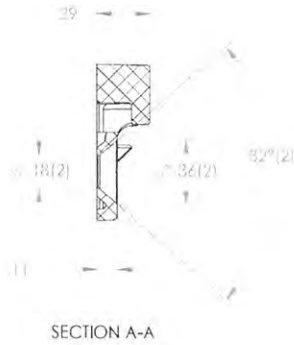

**Test sample complies with these details.
Deviations are noted.**

Report# B1379.01

Date 7/28/11 by ES

NOTES:

1. DIMENSIONS ARE BEFORE FINISHING UNLESS OTHERWISE SPECIFIED.
2. C-LEVEL PRINT TO BE USED FOR CUSTOMER REFERENCE ONLY.
3. E-LEVEL PRINT TO BE USED TO CONTROLLING MANUFACTURING PROCESS.

AFFICABLE SPECIFICATIONS
AES 493, 527

This document and the information and design thereon are proprietary and confidential and shall not be reproduced or disclosed to any third party without the prior written consent of Ashland. Use of this document is limited strictly to the purposes for which the document has been furnished.

Ashland

LOWELL, INDIANA 46356-2349

DRAWN
MAT

CHECKED:

APPROVED FOR TOOLING:

APPROVED FOR PRODUCTION:

DATE
7/19/11

DATE

DATE

DATE

TITLE
KEEPER, DUAL-TECH

SCALE
2:1

ACTUAL MODEL WEIGHT
.051 LBS

PERMISSIBLE TOLERANCES UNLESS OTHERWISE SPECIFIED:

LINEAR .X = ± .030 .XX = ± .015 .XXX = ± .005 (ANGULAR X = ± 1° X.X = ± .5°)

EXPERIMENTAL NO.
XB-

C 1 of 1 C-14161

RB

Last Saved By: rws4326 Tuesday, July 19, 2011 2:20:24 PM

ECO#		LTR.		REVISION DESCRIPTION	INITIALS	DATE
/		/		RELEASE CUSTOMER DRAWING	ECF	3/9/2009

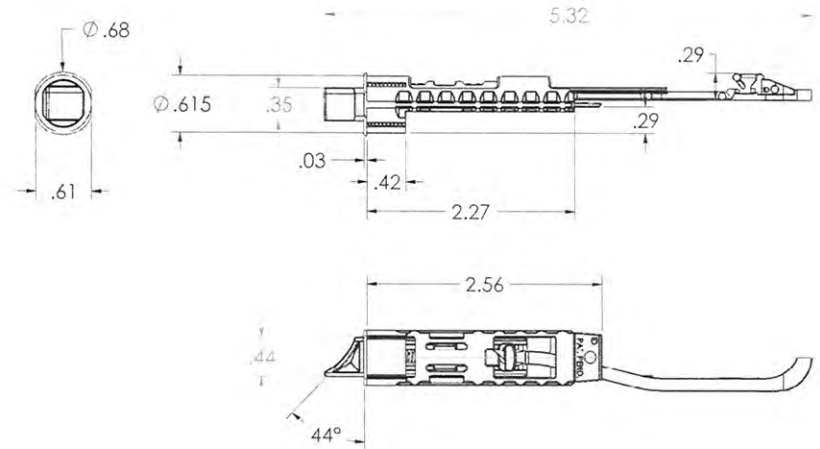
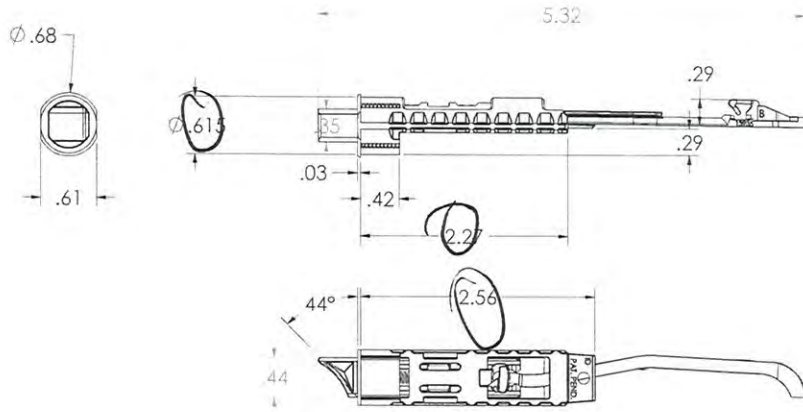

LEFT HAND
80290

RIGHT HAND
80291



Architectural Testing
 Test sample complies with these details.
 Deviations are noted.

Report# B1379.01
 Date 7/28/11 Tech ES

APPLICABLE SPECIFICATIONS
AES or AFR

DRAWN ECF
 CHECKED

DATE 3/09/09
 DATE

TITLE DUAL-TECH RADIUS CONCEALED SLIMLINE LATCH ASSY. LH & RH
 SCALE 1:1
 MATERIAL DESCRIPTION / TOOL INFORMATION

This document and the information and designs thereon are proprietary and confidential and shall not be reproduced or disclosed to unauthorized personnel. Use of this document is limited strictly to the purposes for which this document has been furnished.

APPROVED FOR TOOLING

DATE

ACTUAL MODEL WEIGHT
Wgt. LBS

PERMISSIBLE TOLERANCES UNLESS OTHERWISE SPECIFIED:

Ashland

APPROVED FOR PRODUCTION

DATE

LINEAR .X = ± .030 .XX = ± .015 .XXX = ± .005 / ANGULAR X = ± 1° X.X = ± 5°

POCKFORD BLINDS 61125-7018

EXPERIMENTAL NO. XB-
 SIZE SHEET PART NO. C 1 of 1 80290-80291-064-C-
 REV.

LATCH HOUSING USED IN ASSEMBLY 82100/83100

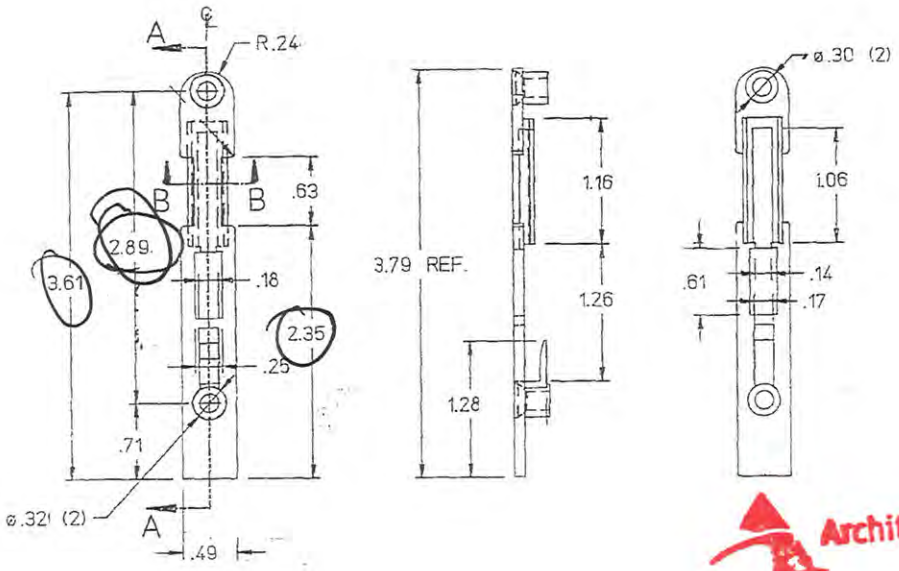

- NOTES:
1. PRINT TO BE USED FOR CUSTOMER REFERENCE ONLY.
 2. FULLY DIMENSIONED ASHLAND PRINT TO BE USED TO CONTROL MANUFACTURING PROCESS.

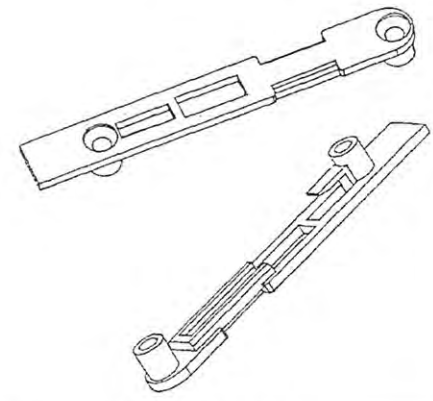

Architectural Testing
 Test sample compliant with these details.
 Deviations are noted.
 Report# B1379.01
 Date 7/28/11 Techn ES

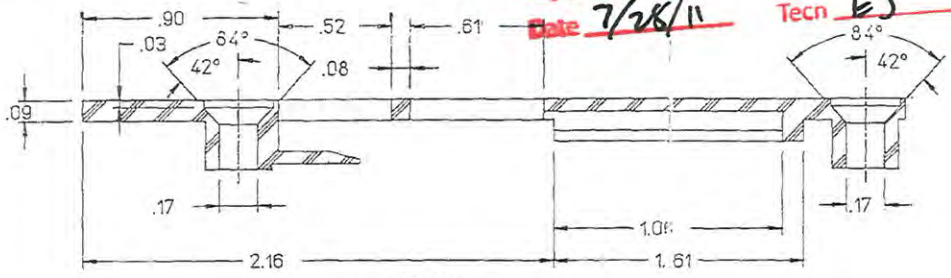

ASHLAND PRODUCTS		
790 WEST COMMERCIAL AVENUE LOWELL, INDIANA 46356		
TELEPHONE NUMBER (219) 696-3950 24 HR. FAX (800) 626-1758		
LATCH HOUSING		
MATERIAL: NYLON		PART NUMBER: C-117
CUSTOMER:	DATE: 11-3-95	
DRAWN BY: M.B.	RELEASED BY: -	
THIS DRAWING IS THE PROPERTY OF ASHLAND PRODUCTS. DESIGN CONCEPT & INFORMATION MAY NOT BE REPRODUCED OR DISCLOSED WITHOUT WRITTEN PERMISSION OF ASHLAND.		DATE: -
TOLERANCES UNLESS OTHERWISE SPECIFIED	DIMENSION IN INCHES UNLESS OTHERWISE SPECIFIED ON DRAWING	DO NOT SCALE DRAWING ASHLAND PART NUMBER 12351 ©
DECIMALS ± TOL		
X .030		
XX .015		
XXX .005		
SCALE= 1:1		
SHEET 1 OF 1		

NOTICE: We reserve the right to make design improvements without notice.

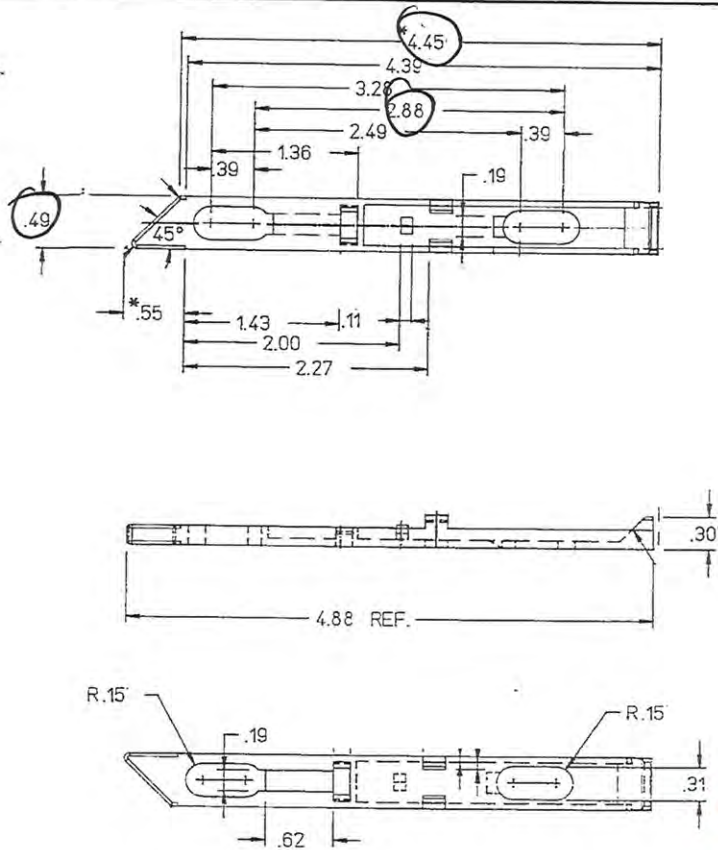

LATCHES USED IN 82100 & 83100 ASSEMBLIES

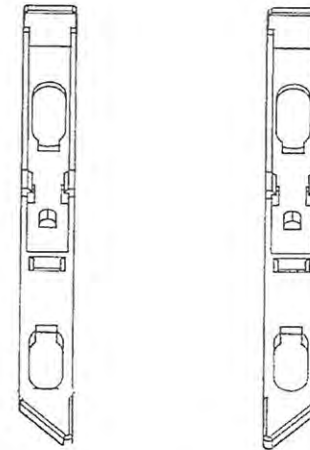

RIGHT HAND LATCH LEFT HAND LATCH
 APCO #12354 APCO #12355
 USED IN 83100 USED IN 82100

NOTES:



Test sample complies with these details.
 Deviations are noted.

Report# B1379.01
 Date 7/28/11 Tech EJ

NOTES:

1. PRINT TO BE USED FOR CUSTOMER REFERENCE ONLY.
2. FULLY DIMENSIONED ASHLAND PRINT TO BE USED TO CONTROL MANUFACTURING PROCESS.

ASHLAND PRODUCTS		
<small>790 WEST COMMERCIAL AVENUE LOWELL, INDIANA 46356 TELEPHONE NUMBER (219) 696-5950 24 HR. FAX (800) 626-1758</small>		
INTERNAL TILT LATCH - RIGHT & LEFT		
MATERIAL: NYLON		
CUSTOMER: SPECTUS	PART NUMBER: C-118	
DRAWN BY: M.B.	DATE: 11-3-95	
RELEASED BY: -	DATE: -	
THIS DRAWING IS THE PROPERTY OF ASHLAND PRODUCTS. DESIGN CONCEPT & INFORMATION MAY NOT BE REPRODUCED OR DISCLOSED WITHOUT WRITTEN PERMISSION OF ASHLAND	TOLERANCES UNLESS OTHERWISE SPECIFIED:	DIMENSION IN INCHES UNLESS OTHERWISE SPECIFIED ON DRAWING
	DECIMALS	± TOL
	X .030	DO NOT SCALE DRAWING
	XX .015	
XXX .005	ASHLAND PART NUMBER	
SCALE= 1 : 1	SHEET 1 OF 2 12354/55®	

NOTICE: We reserve the right to make design improvements without notice.

PART/DWG NO D1000AL-D1000AR-064-C		REV. A
ISSUE DATE	FILE NO.	

ECO#	REV.	REVISION DESCRIPTION	INITIALS	DATE
-	-	RELEASED CUSTOMER DRAWING	ECF	09/19/2007
E9827	A	SEE ECN	ECF	6/25/09

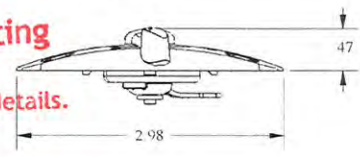
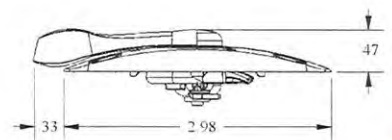
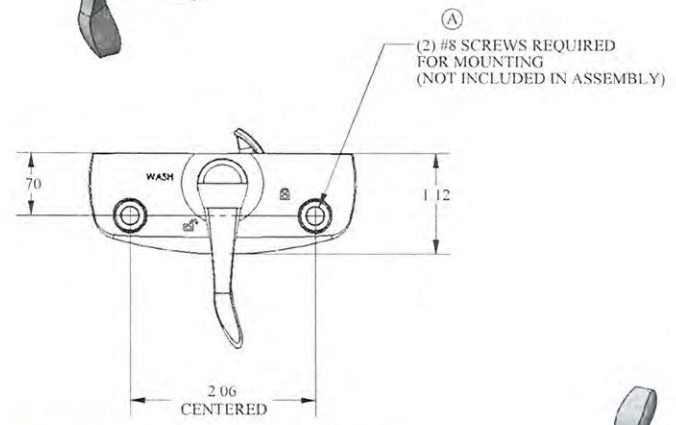
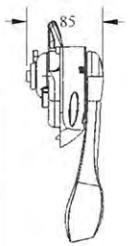
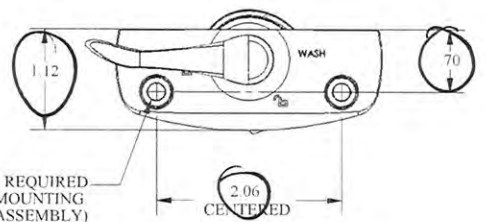
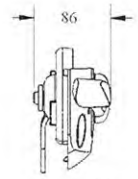

RIGHT HAND
D1000AR
(UNLOCKED POSITION SHOWN)

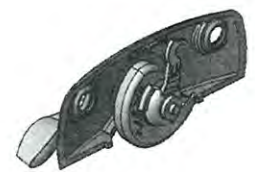

LEFT HAND
D1000AL
(LOCKED POSITION SHOWN)

Architectural Testing
 Test sample complies with these details.
 Deviations are noted.
 Report# B1379.01
 Date 2/28/11 Tech EJ

APPLICABLE SPECIFICATIONS	DRAWN JAS	DATE 9/17/07	TITLE FLUSH MOUNT LOCK ASSEMBLY, LH & RH, CUSTOMER	
AES or AFR	CHECKED	DATE	SCALE 1:1.33333	MATERIAL DESCRIPTION / TOOL INFORMATION
This document and the information and designs thereon are proprietary and confidential and shall not be reproduced or disclosed to unauthorized personnel. Use of this document is limited strictly to the purposes for which the document has been furnished.	APPROVED FOR TOOLING	DATE	ACTUAL MODEL WEIGHT Wgt. LBS.	RAW NO. TEMPER EDGE NO.
	APPROVED FOR PRODUCTION	DATE	PERMISSIBLE TOLERANCES UNLESS OTHERWISE SPECIFIED: LINEAR .X = ± .030 .XX = ± .015 .XXX = ± .005 / ANGULAR X = ± 1° X.X = ± .5°	
Ashland ROCKFORD, ILLINOIS 61125-7018	EXPERIMENTAL NO. XB-	SIZE B	SHEET 1 OF 1	PART NO. D1000AL-D1000AR-064-C
				REV A

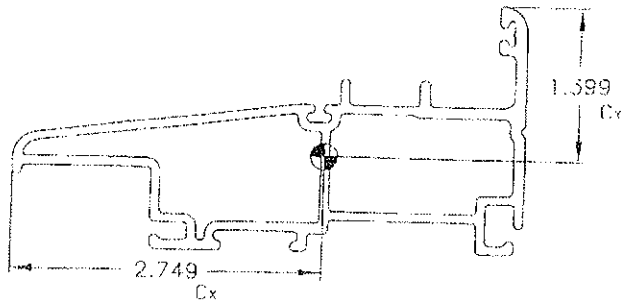

PART #		SV01
WEIGHT		1.0423 lb/ft
AREA		1.3029 in ²
PERIMETER		29.6477 in
MOMENT OF INERTIA	x:	0.3824 in ⁴
	y:	2.5210 in ⁴
RADIUS OF GYRATION	x:	0.5431 in
	y:	1.3910 in
SECTION MODULUS	x:	0.1398 in ³
	y:	1.8020 in ³

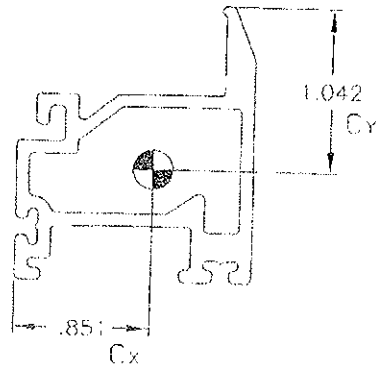

PART #		SV06
WEIGHT		0.4987 lb/ft
AREA		0.6234 in ²
PERIMETER		12.8810 in
MOMENT OF INERTIA	x:	0.1299 in ⁴
	y:	0.1743 in ⁴
RADIUS OF GYRATION	x:	0.4565 in
	y:	0.5287 in
SECTION MODULUS	x:	0.1526 in ³
	y:	0.1673 in ³

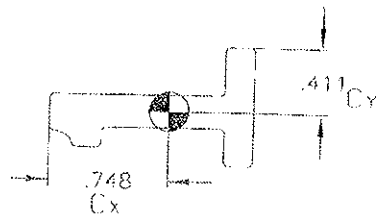

PART #		SV19
WEIGHT		0.3194 lb/ft
AREA		0.3992 in ²
PERIMETER		4.1427 in
MOMENT OF INERTIA	x:	0.0083 in ⁴
	y:	0.0686 in ⁴
RADIUS OF GYRATION	x:	0.1446 in
	y:	0.4146 in
SECTION MODULUS	x:	0.0111 in ³
	y:	0.1669 in ³

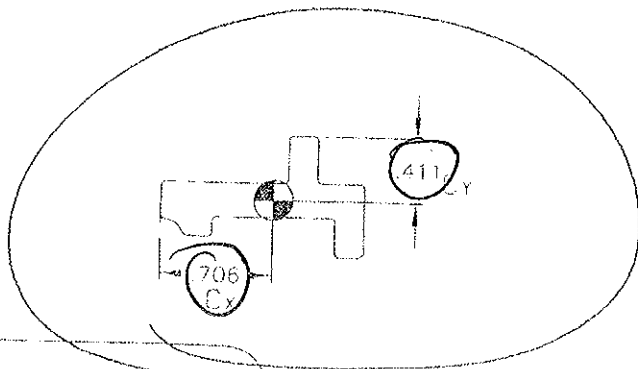

PART #		SV19a
WEIGHT		0.3194 lb/ft
AREA		0.3992 in ²
PERIMETER		4.1170 in
MOMENT OF INERTIA	x:	0.0083 in ⁴
	y:	0.0580 in ⁴
RADIUS OF GYRATION	x:	0.1446 in
	y:	0.3812 in
SECTION MODULUS	x:	0.0118 in ³
	y:	0.1411 in ³

SureView
Fiberglass Window Systems

25101 Chogrin Boulevard
Suite 350
Cleveland, OH 44122

ENGINEERING DATA

Architectural Testing

Issue Date:
AUGUST--2009

Page
19.2

Test sample complies with these details.
Deviations are noted.

Report# R1379 01
Date 7/28/11 Tech EJ

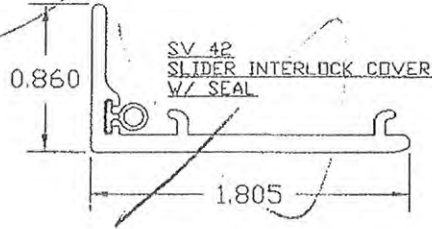
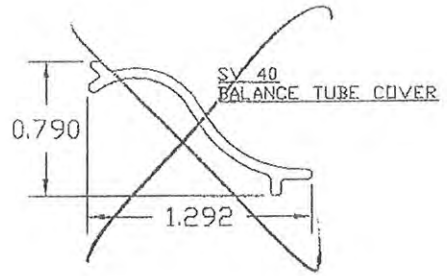
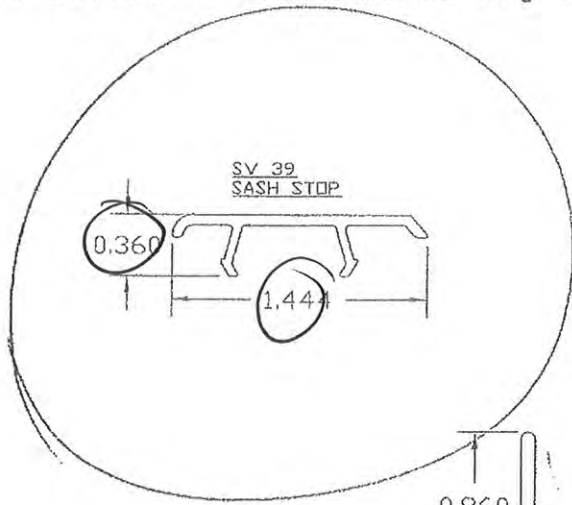

SureView

Fiberglass Window Systems

25101 Chagrin Boulevard
Suite 350
Cleveland, OH 44122

PROFILES - DOUBLE HUNG & SLIDERS

Issue Date:
AUGUST-2009

Page:
2.1.3



Architectural Testing

Test sample complies with these details.
Deviations are noted.

Report# B1379.01

Date 7/28/11 Tech EJ

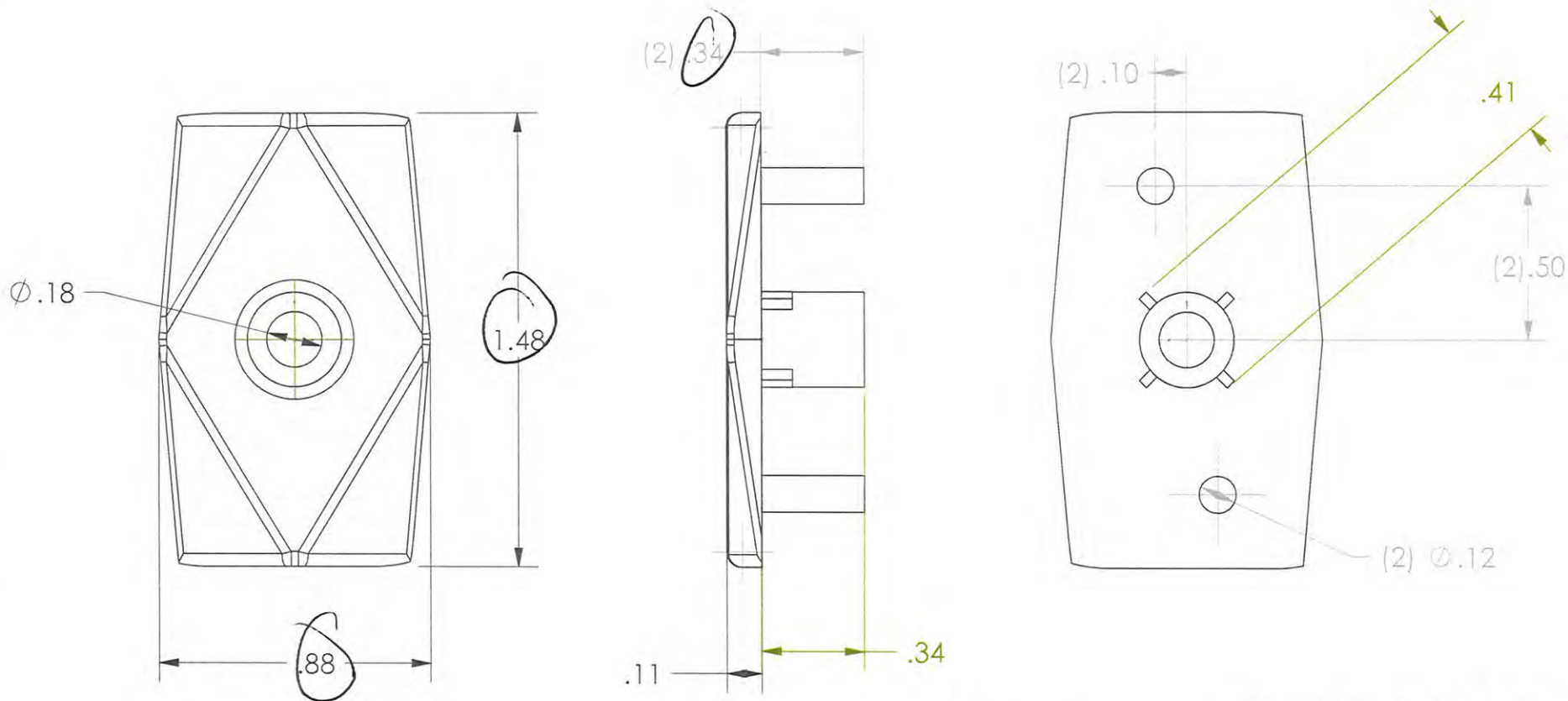

Test sample complies with these details.
Deviations are noted.

Report# B379-01
Date 7/28/11 Tech EJ

NOTES:

1. C-LEVEL PRINT FOR CUSTOMER REFERENCE ONLY.
2. E-LEVEL PRINT TO BE USED TO CONTROL MANUFACTURING PROCESS.

PATENT NUMBER: - STATUS: - INHERITED PATENTS: -

~ PATENT INFORMATION ~

NOTICE: We reserve the right to make design improvements without notice



790 WEST COMMERCIAL AVENUE
LOWELL, INDIANA 46356
TELEPHONE NUMBER (219) 696-5950
24 HR. FAX (800) 626-1758

GLIDE

COLOR: STD

MATERIAL: NYLON 6

CUSTOMER: AHS

DRAWN BY: MAT DATE: 7/28/11 CK. BY: - DATE: -

USED IN ASSY: - PROJ #: - PROTO. #: -

CUBIC INCHES: - COMPONENT: - CAVITATION: -

~ NOTICE ~

THIS DRAWING IS THE
PROPERTY OF ASHLAND
HARDWARE SYSTEMS. DESIGN
CONCEPT & INFORMATION
MAY NOT BE REPRODUCED
USED OR DISCLOSED WITHOUT
WRITTEN PERMISSION FROM
ASHLAND.

TOLERANCES UNLESS
OTHERWISE SPECIFIED
DECIMALS ±TOLERANCE
1 PLC. ~ X .030
2 PLC. ~ .XX .015
3 PLC. ~ .XXX .005
±TOLERANCE GREATER THAN 1.000
AS SHOWN PER INCH

DIMENSIONS ARE IN INCHES
UNLESS OTHERWISE
SPECIFIED ON DRAWING
DO NOT SCALE DRAWING

SCALE = 2:1 SHEET: 1 of 1

ASHLAND PART NUMBER

C-94-05-03-00

PRINT DATE: 7-28-11