

**TEST REPORT**

**Report No.:** C0255.01-602-44

**Rendered to:**

PROFORMANCE MANUFACTURING, INC  
Lone Rock, Wisconsin

**PRODUCT TYPE:** Fixed Window  
**SERIES/MODEL:** Prostar/Ecostar Fixed

**SPECIFICATION:** AAMA/WDMA/CSA 101/I.S.2/A440-11, *NAFS - North American Fenestration Standard/Specification for Windows, Doors, and Skylights*

AAMA/WDMA/CSA 101/I.S.2/A440-08, *NAFS - North American Fenestration Standard/Specification for Windows, Doors, and Skylights*

Title	Summary of Results
Primary Product Designator	Class CW-PG40 Size Tested: 2184 x 2438 (86 x 96)-FW
Positive Design Pressure	2160 Pa (45.12 psf)
Negative Design Pressure	-1920 Pa (-40.10 psf)
Air Infiltration	<0.05 L/s/m <sup>2</sup> (<0.01 cfm/ft <sup>2</sup> )
Canadian Air Infiltration/Exfiltration Level	Fixed
Water Penetration Resistance Test Pressure	580 Pa (12.11 psf)

**Test Completion Date:** 06/13/2012

Reference must be made to Report No. C0255.01-602-44, dated 07/10/12 for complete test specimen description and detailed test results.



**1.0 Report Issued To:** Proformance Manufacturing  
P.O. Box 58/750 North County Line Road  
Lone Rock, Wisconsin 53556

**2.0 Test Laboratory:** Architectural Testing, Inc.  
5906 Saxon Avenue  
Schofield, Wisconsin  
715-241-8624

**3.0 Project Summary:**

**3.1 Product Type:** Fixed Window

**3.2 Series/Model:** Prostar/ Ecostar Fixed

**3.3 Compliance Statement:** Results obtained are tested values and were secured by using the designated test methods. The specimen tested successfully met the performance requirements for a **Class CW-PG40 Size Tested: 2184 x 2438 (86 x 96)-FW** rating.

**3.4 Test Date:** 06/13/2012

**3.5 Test Record Retention End Date:** All test records for this report will be retained until July 10, 2016.

**3.6 Test Location:** Architectural Testing Inc. test facility in Schofield, Wisconsin. Calibration of test equipment was performed by Architectural Testing in accordance with AAMA 205-01 "In-Plant Testing Guidelines for Manufacturers and Independent Laboratories".

**3.7 Test Sample Source:** The test specimen was provided by the client Representative samples of the test specimens will be retained by Architectural Testing for a minimum of four years from the test completion date.

**3.8 Drawing Reference:** The test specimen drawings have been reviewed by Architectural Testing and are representative of the test specimen reported herein. Test specimen construction was verified by Architectural Testing per the drawings located in Appendix B. Any deviations are documented herein or on the drawings.

**3.9 List of Official Observers:**

<u>Name</u>	<u>Company</u>
Jerry Beranek	Proformance Manufacturing, Inc.
Aaron Fersti	Proformance Manufacturing, Inc.
Jeffrey Zibton	Architectural Testing, Inc.

**4.0 Test Specification(s):**

AAMA/WDMA/CSA 101/I.S.2/A440-11, *NAFS - North American Fenestration Standard/Specification for Windows, Doors, and Skylights*

AAMA/WDMA/CSA 101/I.S.2/A440-08, *NAFS - North American Fenestration Standard/Specification for Windows, Doors, and Skylights*

**5.0 Test Specimen Description:****5.1 Product Sizes:**

Overall Area: 5.3 m <sup>2</sup> (57.3 ft <sup>2</sup> )	Width		Height	
	millimeters	inches	millimeters	inches
Overall size	2184	86	2438	96

**5.2 Frame Construction:**

Frame Member	Material	Description
Head, sill and jambs	Fiberglass	Pultruded

	Joinery Type	Detail
All corners	Mitered	Corner keyed and silicone injected

**5.3 Weatherstripping:** No weatherstripping was utilized.

**5.4 Glazing:** *No conclusions of any kind regarding the adequacy or inadequacy of the glass in any glazed test specimen can be made.*

Glass Type	Spacer Type	Interior Lite	Exterior Lite	Glazing Method
19 mm (3/4") IG	7 mm (1/4") U-Shaped spacer system	6 mm (1/4")	6 mm (1/4")	The glass was set from the interior against silicone sealant. Vinyl glazing beads were used at the interior.

Location	Quantity	Daylight Opening		Glass Bite
		millimeters	inches	
Fixed opening	1	2038 x 2292	80-1/4 x 90-1/4	5/8"

**5.0 Test Specimen Description:** (Continued)

**5.5 Drainage:** No drainage was utilized.

**5.6 Hardware:** No hardware was utilized.

**5.7 Reinforcement:** No reinforcement was utilized.

**6.0 Installation:**

The specimen was installed into a Spruce-Pine-Fir wood buck. The rough opening allowed for a 1/4" shim space. The exterior perimeter of the window was sealed with sealant.

Location	Anchor Description	Anchor Location
Window perimeter	3/4" x 3/4" blind stops	Interior and exterior perimeter
Frame head and jambs	3" drywall screws	Approximately 34" to 39" on center

**7.0 Test Results:** The temperature during testing was 21°C (70°F). The results are tabulated as follows:

Title of Test	Results	Allowed	Note
<b>Air Leakage,</b> Infiltration per ASTM E 283 at 75 Pa (1.57 psf)	<0.05 L/s/m <sup>2</sup> (<0.01 cfm/ft <sup>2</sup> )	1.5 L/s/m <sup>2</sup> (0.3 cfm/ft <sup>2</sup> ) max.	1
<b>Air Leakage,</b> Infiltration per ASTM E 283 at 300 Pa (6.27 psf)	<0.05 L/s/m <sup>2</sup> (<0.01 cfm/ft <sup>2</sup> )	Report Only	1
<b>Air Leakage,</b> Exfiltration per ASTM E 283 at 75 Pa (1.57 psf)	<0.05 L/s/m <sup>2</sup> (<0.01 cfm/ft <sup>2</sup> )	1.5 L/s/m <sup>2</sup> (0.3 cfm/ft <sup>2</sup> ) max.	1
<b>Air Leakage,</b> Exfiltration per ASTM E 283 at 300 Pa (6.27 psf)	<0.05 L/s/m <sup>2</sup> (<0.01 cfm/ft <sup>2</sup> )	Report Only	1
<b>Canadian Air Infiltration/Exfiltration Level</b>	Fixed	0.2 L/s/m <sup>2</sup> (0.04 cfm/ft <sup>2</sup> ) max.	
<b>Water Penetration,</b> per ASTM E 547 at 220 Pa (4.59 psf)	N/A	No leakage	2

**7.0 Test Results:** (Continued)

<b>Title of Test</b>	<b>Results</b>	<b>Allowed</b>	<b>Note</b>
<b>Uniform Load Deflection,</b> per ASTM E 330	N/A	N/A	2
<b>Uniform Load Structural,</b> per ASTM E 330	N/A	N/A	2
<b>Forced Entry Resistance,</b> per ASTM F 588, Type: D- Grade: 40	Pass	No entry	
<b>Optional Performance</b>			
<b>Water Penetration,</b> per ASTM E 547 at 580 Pa (12.11 psf)	Pass	No leakage	
<b>Uniform Load Deflection,</b> per ASTM E 330 taken at sill +2160 Pa (+45.11 psf) -2160 Pa (-45.11 psf)	2.8 mm (0.11") 3.6 mm (0.14")	12.2 mm (0.48") max. 12.2 mm (0.48") max.	3, 4
<b>Uniform Load Structural,</b> per ASTM E 330 taken at sill +3240 Pa (+67.67 psf) -2880 Pa (-60.15 psf)	<0.3 mm (<0.01") 0.5 mm (0.02")	6.4 mm (0.25") max. 6.4 mm (0.25") max.	3, 4

*Note 1: The tested specimen meets (or exceeds) the performance levels specified in AAMA/WDMA/CSA 101/1.S.2/A440 for air leakage resistance.*

*Note 2: The client opted to start at a pressure higher than the minimum required. Test results are reported under Optional Performance.*

*Note 3: Loads were held for 10 seconds.*

*Note 4: Tape and film were not used to seal against air leakage during structural testing.*



Architectural Testing will service this report for the entire test record retention period. Test records that are retained such as detailed drawings, datasheets, representative samples of test specimens, or other pertinent project documentation will be retained by Architectural Testing, Inc. for the entire test record retention period.

This report does not constitute certification of this product nor an opinion or endorsement by this laboratory. It is the exclusive property of the client so named herein and relates only to the specimen(s) tested. This report may not be reproduced, except in full, without the written approval of Architectural Testing, Inc.

For ARCHITECTURAL TESTING, Inc.

---

Jeffrey M. Zibton  
Project Manager

---

Wanda L. Matis  
Technical Service Manager

JMZ:jrb:asm

Attachments (pages): This report is complete only when all attachments listed are included.

Appendix-A: Alteration Addendum (1)

Appendix-B: Drawings (6)



## Appendix A

### Alteration Addendum

**Alteration #1:** Date - \_06/13/2012  
Cause for alteration – Water leakage  
Remedial action taken – Face seal applied to corner miters



**Architectural Testing**

Test Report No.: C0255.01-602-44

Report Date: 07/10/12

## **Appendix B**

### **Drawings**

Picture BOM

	Description	Vendor	Quantity	Part #
✓	Picture Frame	Teel Plastics		P0007
✓	Glazing Bead	Teel Plastics		P0136
✓	Frame Keys	Flambeau	4	817711AE
✓	Silicone		3 oz	
✓	Glue	Novagard	120 grams	
✓	Glass	Cardinal		1 5.7 Tempered LoE366

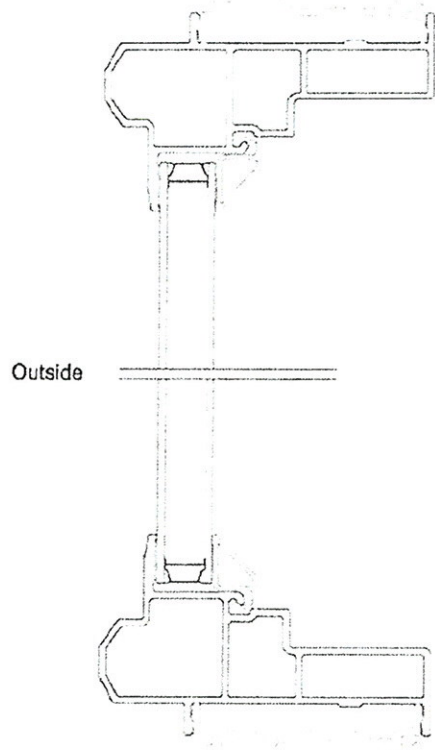

PMI Picture Window End View

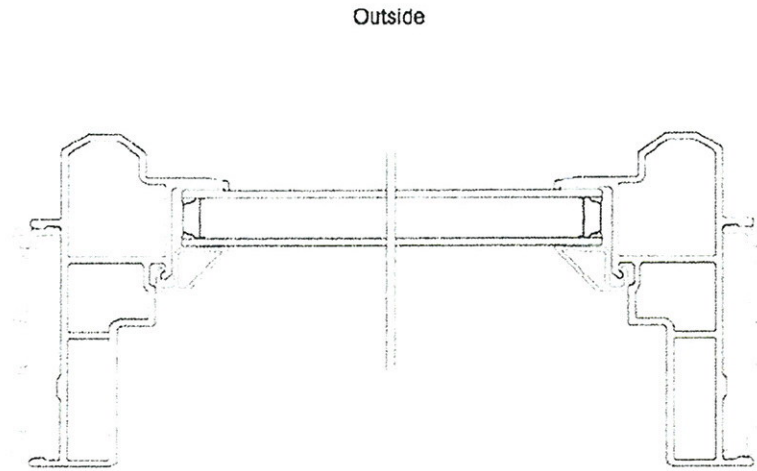

PMI Picture Window Top View

REV	DATE	BY	CHK

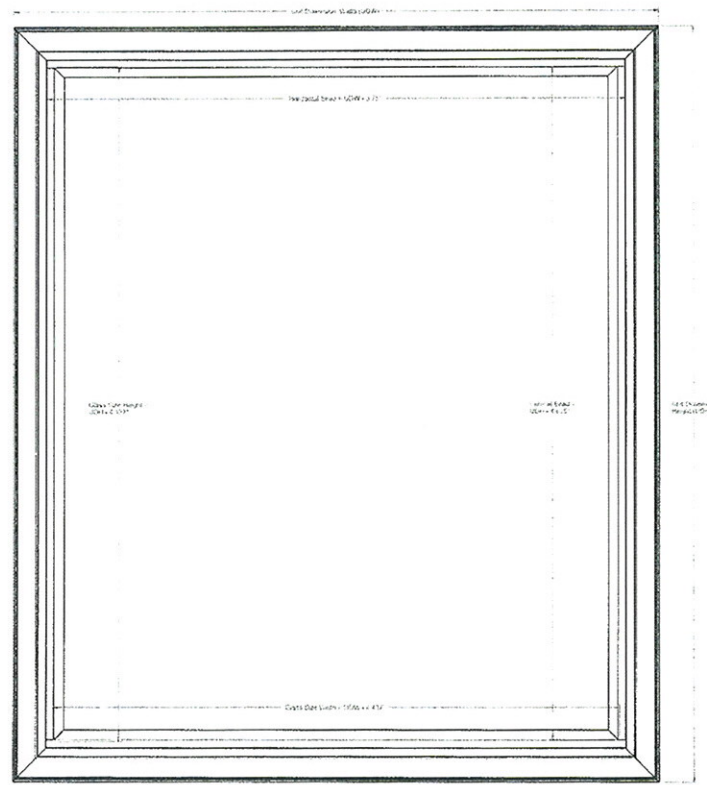
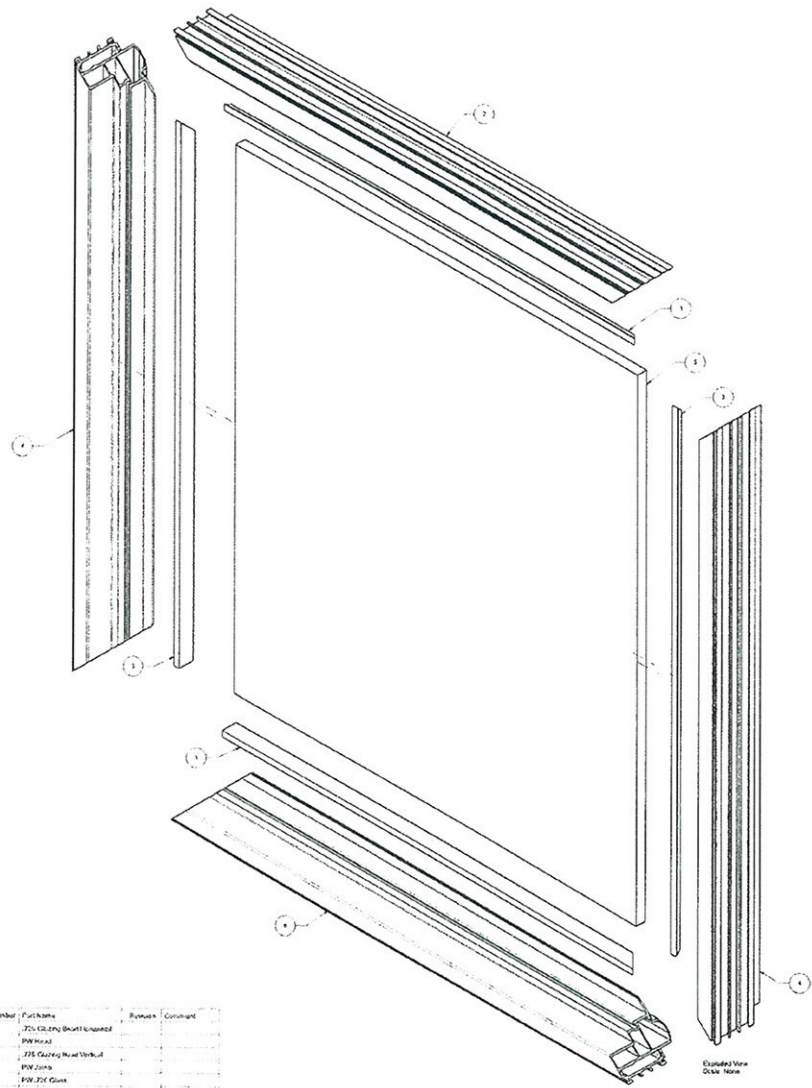

Rev	Quantity	Part Number	Part Name	Remark	Comment
1	4	J215 (3.25x) Bevel Unfinished			
2	1	PW Head			
3	2	J215 Flanging Bevel Worked			
4	2	PW Sash			
5	1	PW J215 Glass			
6	1	PW Sill			

Excluded Note  
Disc: None

<p>Use Industry Standard Practices unless Otherwise Specified.</p> <p>Project: <b>ECOSAIR</b></p> <p>Client: <b>ECOSAIR</b></p> <p>Location: <b>1950 Cypress Woods</b></p> <p>Contract No: <b>1950Cypress Woods</b></p>	<p>Prepared by: <b>ECOSAIR</b></p> <p>Checked by: <b>ECOSAIR</b></p> <p>Approved by: <b>ECOSAIR</b></p>	<p>DATE: <b>08.16.2011</b></p> <p>SCALE: <b>25x</b></p>	<p><b>ECOSAIR</b></p> <p>1950 Cypress Woods</p> <p>1950 Cypress Woods</p>
---	---	---	---



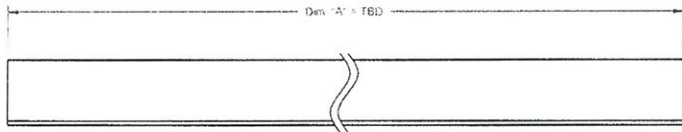

Trim Detail  
Sash: 1x

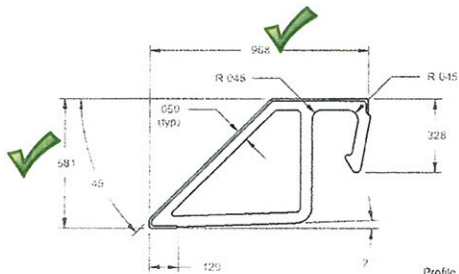

Profile Detail  
Scale: 2x

Customer Approval

Sign name on line above

Date

Print name on line above

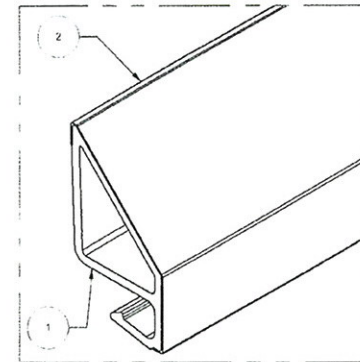

REVISIONS				
ZONL	REV	DESCRIPTION	DATE	APPROVAL
	01	Added Cap Area	01/28/2011	Test

Item #	PMI Part #	Part Name	Cost Center	Rev.	Comment
1	P0136	Glazing Bead .726	Area: .116", Outer Perim: 3.201", Inner Perim: 1.781"	.01	
2		Glazing Bead Cap .726	Area: .0139", Perimeter: 2.791"		.010" Nominal Cap Wall Thickness

Note: Industry Standard Tolerances Unless Otherwise Specified.

The contents of this document or electronic media are confidential and proprietary information of Performance Manufacturing, Inc. Distribution or reproduction of this information without the express written consent of Performance Manufacturing, Inc. is prohibited. © 2010 PMI All rights reserved.

DRAWN PMI Engineering	DATE 01.26.2011
CHECKED	
QA	
MFG	
APPROVED	



Performance Manufacturing, Inc  
750 North County Line Road  
Lone Rock, WI 53556  
www.pmi-windows.com  
608.583.7200  
608.583.7060 Fax

SIZE B	DWG NO PMI-106-01	DWG Name Glazing Bead .726	REV .01
SCALE As Noted	Directory PMI\Engineering\Accessory\Sash	SHEET 1 of 1	

4

3

2

1

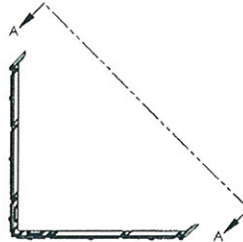
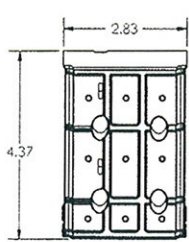
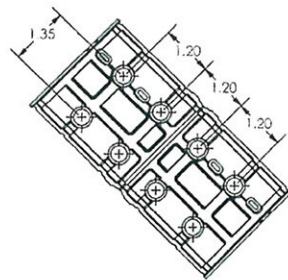
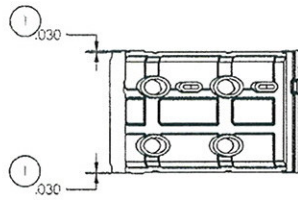

VIEW A-A

Double Hung Head Key - Part A (PN DH Head Part A)

Double Hung Head Key - Parts A & B Assembly

CUSTOMER SIGN-OFF	
Company	
Signature	
Printed Name	
Date	

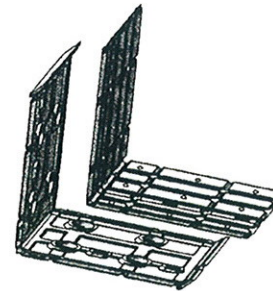

- Notes
1. Material: ABS
  2. Finish: EDM
  3. Color: Natural
  4. Nominal Wall Thickness: 0.080"
  5. Tooling Note: Radius corners up to 0.020 as needed except where it would cause interference between mating surfaces.

D

C

D

C

B

A

B

A

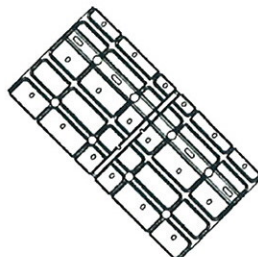

VIEW B-B

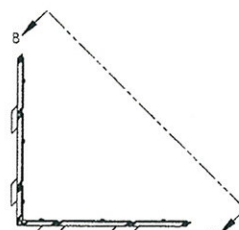
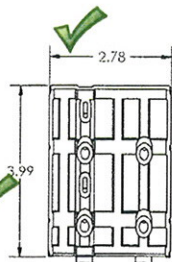

Double Hung Head Key - Part B (PN DH Head Part B)

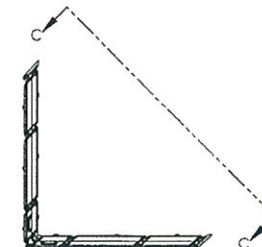
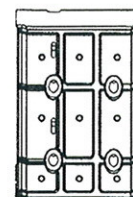
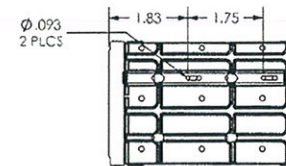

VIEW C-C

PROPRIETARY AND CONFIDENTIAL  
 DIE BEZONDERE EIGENSCHAP VAN  
 DE FABRIEK VAN DE NEDERLANDSE  
 RIJSTRIJKS-INDUSTRIE-MAATSCHAPPIJ  
 N.V. ROTTERDAM

SHT	1	Scale	T2	BFI No.	NA	Drawn By	RDL	Date	1-18-11
OF	1	Description	Double Hung Head Key Assembly						
Customer	PMI	Dwg No.	S-10341						

REV	ECR	DESCRIPTION	DATE	BY	APR
1	---	Added 030 humps	5-20-11	RDL	
0	---	Released for Tooling	1-20-11	RDL	



REVISIONS				
ZONE	REV	DESCRIPTION	DATE	APPROVED

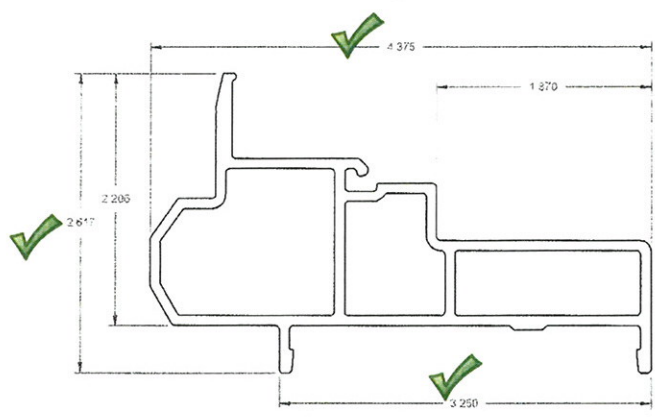
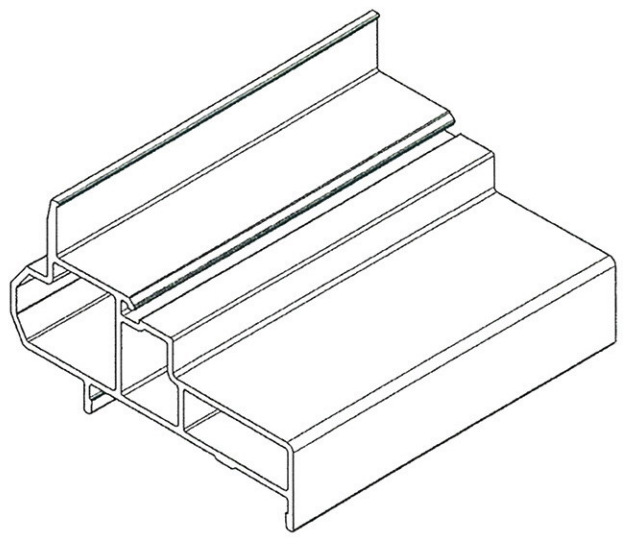
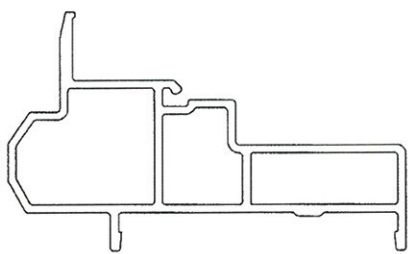
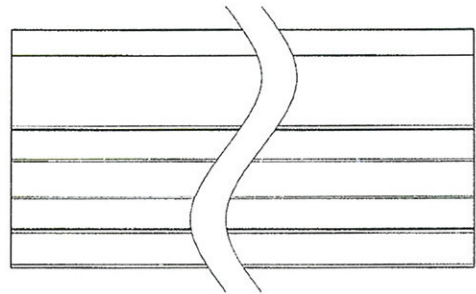

<p>Note: Industry Standard Tolerances Unless Otherwise Specified.</p> <p>The contents of this document or electronic media are confidential and proprietary information of Proformance Manufacturing, Inc. Distribution or reproduction of this information without the express written consent of Proformance Manufacturing, Inc is prohibited. © 2010 PMI! All rights reserved.</p>	DRAWN <b>PMI Engineering</b>	DATE	 <p>Proformance Manufacturing, Inc                  750 North County Line Road                  Lone Rock, WI 53556                  www.pmi-windows.com                  608.583.7200                  608.583.7060 Fax</p>
	CHECKED		
	QA		
	MFG		
	APPROVED		
SIZE <b>B</b>	DWG NO.	DWG Name	REV
SCALE As Noted	Directory	SHEET	